

GPS Module Datasheet

Name: Ultra High Sensitivity and Low Power GPS Receiver Module

Model No.: SKM56-J

Revision: 01

Revision History:

Revision	Description	Approved	Date
001	Initial release to 001	Woody	20140806

General Description

The SKM56-J is a complete GPS engine module that features super sensitivity, ultra low power and small form factor. The GPS signal is applied to the antenna input of module, and a complete serial data message with position, velocity and time information is presented at the serial interface with NMEA protocol or custom protocol.

It is based on the high performance features of the MediaTek MT3337 single-chip architecture, Its -165dBm tracking sensitivity extends positioning coverage into place like urban canyons and dense foliage environment where the GPS was not possible before. The small form factor and low power consumption make the module easy to integrate into portable device like PNDs, mobile phones, cameras and vehicle navigation systems.

Applications

- LBS (Location Based Service)
- PND (Portable Navigation Device)
- Vehicle navigation system
- Mobile phone

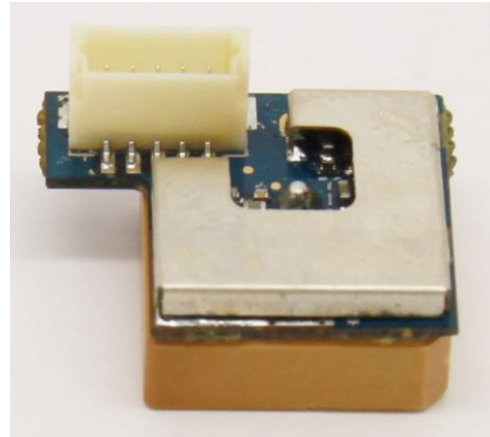

Figure 1: SKM56-J Top View

Features

- Ultra high sensitivity: -165dBm
- Extremely fast TTFF at low signal level
- Built-in 12 multi-tone active interference canceller
- Ultra low power consumption
- $\pm 10\text{ns}$ high accuracy time pulse (1PPS)
- NMEA Output: GGA,GSA,GSV,RMC
- Advanced Features: AlwaysLocate; AIC
- QZSS、SBAS (WAAS, EGNOS, MSAS, GAGAN)
- RoHS compliant (Lead-free)

Pin Assignment

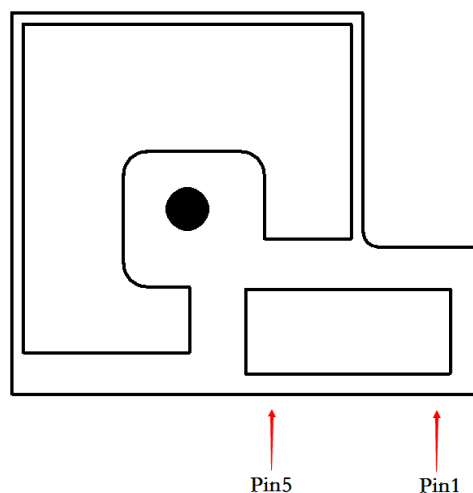

Figure 2: SKM56-J Pin Package

Pin Description

Pin No.	Pin name	I/O	Description	Remark
1	VCC	I	Module Power Supply	
2	GND	G	Ground	
3	TXD	O	UART Serial Data Output	Leave open if not used
4	RXD	I	UART Serial Data Input	
5	VBACKUP	I	RTC and backup SRAM power	Leave open if not used

Interfaces Configuration

Power Supply

Regulated power for the SKM56-J is required. The input voltage Vcc should be 3.0V to 4.2V range, current is no less than 100mA. Suitable decoupling must be provided by external decoupling circuitry (10uF and 1uF). It can reduce the Noise from power supply and increase power stability.

Main power supply Vcc current varies according to the processor load and satellite acquisition. Maximum Vcc peak current is about 30 mA during acquisition.

Backup Battery Power

In case of a power failure on pin Vcc, real-time clock and backup RAM are supplied through pin V_BCKP. This enables the SKM56-J GPS Receiver to recover from power failure with either a hot start or a warm start (depending on the duration of Vcc outage). If no Backup Battery is connected, the receiver performs a cold start upon powered up. Backup Battery Power V_BCKP draws typically 7 uA current in backup state.

UART Ports

The module supports one full duplex serial channels UART. The serial connections are at 2.85V LVTTTL logic levels, if need different voltage levels, use appropriate level shifters. the data format is however fixed: X, N, 8, 1, i.e. X baud rate, no parity, eight data bits and one stop bit, no other data formats are supported, LSB is sent first. The modules default baud rate is set up 9600bps.

Advanced Software Features

AlwaysLocate™

AlwaysLocate™ is an intelligent controller of periodic mode. Depending on the environment and motion conditions, GPS module can adaptively adjust working/standby time to achieve balance of positioning accuracy and power consumption. In this mode, the host CPU does not need to control GPS module until the host CPU needs the GPS position data. The following flow chart is an example to make GPS module go into AlwaysLocate™ mode and then back to normal operation mode.

Embedded Logger function

The Embedded Logger function don't need host CPU (MCU) and external flash to handle the operation, GPS Engine will use internal flash (embedded in GPS chipset) to log the GPS data (Data format: UTC, Latitude, longitude, Valid, Checksum), the max log days can up to 2 days under AlwaysLocate™ condition.

AIC_Multi-tone active interference canceller

Because different application (Wi-Fi, GSM/GPRS, 3G/4G, Bluetooth) are integrated into navigation system, the harmonic of RF signal will influence the GPS reception, The multi-tone active-interference canceller can reject external RF interference which come from other active components on the main board, to improve the capacity of GPS reception without any needed HW change in the design. SKM56-J can cancel up to 12 independent channel interference continuous wave.

Performance Specification

Parameter	Specification	
Receiver Type	L1 frequency band, C/A code, 22 Tracking / 66 Acquisition-Channel	
Sensitivity	Tracking	-165dBm Typical
	Acquisition	-148dBm Typical
Accuracy	Position	3.0m CEP50 without SA(Typical Open Sky)
	Velocity	0.1m/s without SA
	Timing (PPS)	10ns RMS
Acquisition Time	Cold Start	23s(Typical Open Sky)
	Warm Start	23s
	Hot Start	1s
	Re-Acquisition	<1s
Assisted GPS support	EPO	
Power Consumption	Tracking	17mA @3.3V Typical
	Acquisition	20mA @3.3V
Navigation Data Update Rate	Max 10Hz	Default 1Hz
Operational Limits	Altitude	Max 18,000m
	Velocity	Max 515m/s
	Acceleration	Less than 4g

Electrical Characteristics

Absolute Maximum Rating

Parameter	Symbol	Min	Max	Units
Power Supply				
Power Supply Volt.	VCC	-0.3	4.3	V
Input Pins				
Input voltage on any input connection	VIO	-0.3	3.6	V
Backup Battery	V_BCKP	-0.3	4.3	V
RF input power	RF_IN		10	dBm
Human Body Model ESD capability	RF_IN		2000	V
Machine Model ESD capability	RF_IN		100	V
Environment				
Storage Temperature	Tstg	-40	125	°C
Peak Reflow Soldering Temperature <10s	Tpeak		260	°C
Humidity			95	%

Note: Absolute maximum ratings are stress ratings only, and functional operation at the maxims is not guaranteed. Stress beyond the limits specified in this table may affect device reliability or cause permanent damage to the device. For functional operating conditions, refer to the operating conditions tables as follow.

The SKM56-J module is Electrostatic Sensitive Device (ESD) and may be damaged with ESD or spike voltage. Although it has built-in ESD protection circuitry at digital I/O, please handle with care to avoid permanent malfunction or performance degradation. Note that RFIN has no ESD protection circuits.

Operating Conditions

Parameter	Symbol	Condition	Min	Typ	Max	Units
Power supply voltage	Vcc		3	3.3	4.2	V
Backup Battery	V_BCKP		2	3.3	4.2	V
Supply current, navigation	Icc	Vcc=3.3V		17	21	mA
Supply current, backup state	Ibckp	Vcc=3.3V		7		uA
Input high voltage	V _{IH}		2		3.6	V
Input low voltage	V _{IL}		-0.3		0.8	V
Output high voltage	V _{OH}		2.4		3.1	V
Output low voltage	V _{OL}		-0.3		0.4	V
Operating temperature	Topr		-40		85	°C

Mechanical Specification

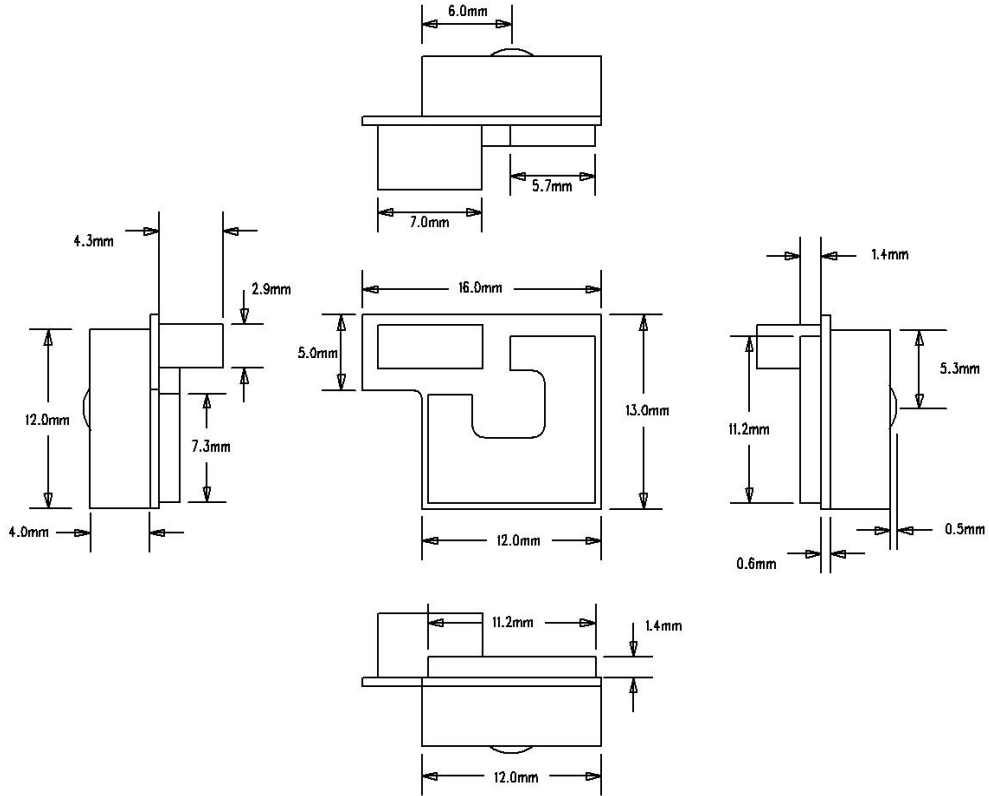

Figure 3: SKM56-J Dimensions

Reference design schematic

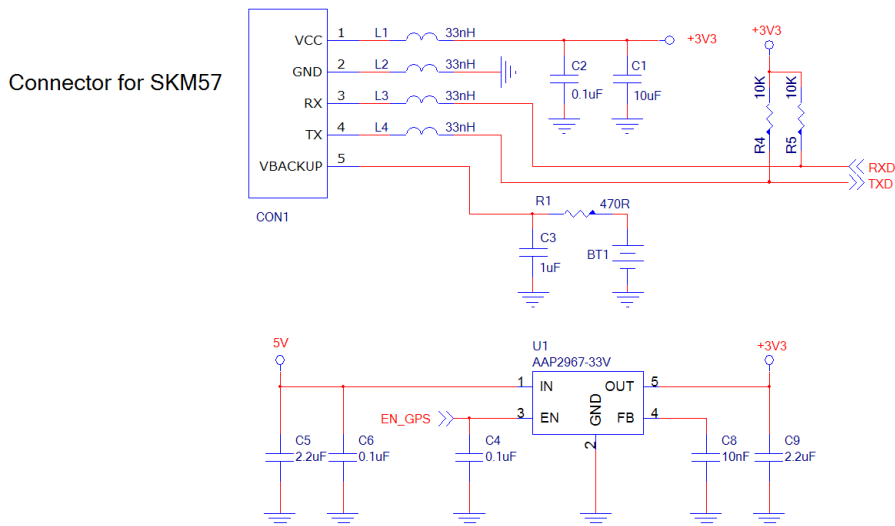

Figure 5: SKM56-J Typical Reference design schematic

Software Protocol

NMEA 0183 Protocol

The NMEA protocol is an ASCII-based protocol, Records start with a \$ and with carriage return/line feed. GPS specific messages all start with \$GPxxx where xxx is a three-letter identifier of the message data that follows. NMEA messages have a checksum, which allows detection of corrupted data transfers.

The Skylab SKM56-J supports the following NMEA-0183 messages: GGA, GSA, GSV, RMC. The module default NMEA-0183 output is set up GGA, GSA, RMC, GSV, and default baud rate is set up 9600bps.

Table 1: NMEA-0183 Output Messages

NMEA Record	Description	Default
GGA	Global positioning system fixed data	Y
GSA	GNSS DOP and active satellites	Y
GSV	GNSS satellites in view	Y
RMC	Recommended minimum specific GNSS data	Y

GGA-Global Positioning System Fixed Data

This sentence contains the position, time and quality of the navigation fix.

See RMC for Fix Status, Fix Mode, Fix Date, Speed, and True Course.

See GSA for Fix Type, PDOP, and VDOP.

\$GPGGA,021514.000,2232.1799,N,11401.1823,E,1,6,1.25,84.0,M,-2.2,M,,*74

Table 2: GGA Data Format

Name	Example	Units	Description
Message ID	\$GPGGA		GGA protocol header
UTC Position	021514.000		hhmmss.sss
Latitude	2232.1799		ddmm.mmmm
N/S indicator	N		N=north or S=south
Longitude	11401.1823		dddmm.mmmm
E/W Indicator	E		E=east or W=west
Position Fix Indicator	1		See Table 2-1
Satellites Used	6		Range 0 to 12
HDOP	1.25		Horizontal Dilution of Precision
MSL Altitude	84.0	meters	Altitude (referenced to the Ellipsoid)
AltUnit	M	meters	Altitude Unit
GeoSep	-2.2	meters	Geoidal Separation
GeoSepUnit	M	meters	Geoidal Separation Unit
Age of Diff.Corr.	<Null>	second	Null fields when it is not Used
Diff.Ref.Station ID	<Null>		Null fields when it is not Used
Checksum	*74		

EOL	<CR> <LF>		End of message termination
-----	-----------	--	----------------------------

Table 2-1: Position Fix Indicators

Value	Description
0	Fix not available or invalid
1	GPS SPS Mode, fix valid
2	Differential GPS, SPS Mode, fix valid
3	GPS PPS Mode, fix valid

GSA-GNSS DOP and Active Satellites

This sentence contains the mode of operation, type of fix, PRNs of the satellites used in the solution as well as PDOP, HDOP and VDOP.

\$GPGSA,A,3,26,05,18,15,27,29,,,,,,1.52,1.25,0.87*0F

Table 3: GSA Data Format

Name	Example	Units	Description
Message	\$GPGSA		GSA protocol header
Mode 1	A		See Table 3-2
Mode 2	3		See Table 3-1
ID of satellite used	26		Sv on Channel 1
ID of satellite used	05		Sv on Channel 2
...
ID of satellite used	<Null>		Sv on Channel 12 (Null fields when it is not Used)
PDOP	1.52		Position Dilution of Precision
HDOP	1.25		Horizontal Dilution of Precision
VDOP	0.87		Vertical Dilution of Precision
Checksum	*0F		
EOL	<CR> <LF>		End of message termination

Table 3-1: Mode 1

Value	Description
1	Fix not available
2	2D Fix
3	3D Fix

Table 3-2: Mode 2

Value	Description
M	Manual-forced to operate in 2D or 3D mode
A	Automatic-allowed to automatically switch 2D/3D

GSV-GNSS Satellites in View

This sentence contains the PRNs, azimuth, elevation, and signal strength of all satellites in view.

\$GPGSV,3,1,12,15,79,333,42,42,50,127,,29,45,263,44,02,36,124,30*7E

\$GPGSV,3,2,12,26,36,226,34,05,35,046,22,27,33,161,29,21,16,319,*7D

\$GPGSV,3,3,12,10,15,066,31,18,14,285,45,24,12,319,15,08,09,047,18*7E

Table 4: GSV Data Format

Name	Example	Units	Description
Message ID	\$GPGSV		GSV protocol header
Number of Message	3		Total number of GSV sentences (Range 1 to 3)
Message Number	1		Sentence number of the total (Range 1 to 3)
Satellites in View	12		Number of satellites in view
Satellite ID	15		Channel 1(Range 01 to 32)
Elevation	79	degrees	Channel 1(Range 00 to 90)
Azimuth	333	degrees	Channel 1(Range 000 to 359)
SNR(C/NO)	42	dB-Hz	Channel 1(Range 00 to 99, null when not tracking)
...			...
Satellite ID	02		Channel 4(Range 01 to 32)
Elevation	36	degrees	Channel 4(Range 00 to 90)
Azimuth	124	degrees	Channel 4(Range 000 to 359)
SNR(C/NO)	30	dB-Hz	Channel 4(Range 00 to 99, null when not tracking)
Checksum	*7E		
EOL	<CR> <LF>		End of message termination

Depending on the number of satellites tracked multiple messages of GSV data may be required.

RMC-Recommended Minimum Specific GNSS Data

This sentence contains the recommended minimum fix information.

See GGA for Fix Quality, Sats Used, HDOP, Altitude, Geoidal Separation, and DGPS data.

See GSA for Fix Type, PDOP and VDOP.

\$GPRMC,023345.000,A,2232.1767,N,11401.1953,E,0.18,151.55,100410,,A*6B

Table 5: RMC Data Format

Name	Example	Units	Description
Message ID	\$GPRMC		RMC protocol header
UTS Position	023345.000		hhmmss.sss
Status	A		A=data valid or V=data not valid
Latitude	2232.1767		ddmm.mmmm
N/S Indicator	N		N=north or S=south
Longitude	11401.1953		dddmm.mmmm
E/W Indicator	E		E=east or W=west
Speed Over Ground	0.18	Knots	
Course Over Ground	151.55	Degrees	True Course
Date(UTC)	100410		ddmmyy
Magnetic variation	<Null>	Degrees	Null fields when it is not Used

Magnetic Variation Direction	<Null>		E=east or W=west (Null fields when it is not Used)
Fix Mode	A		A=autonomous, N = No fix, D=DGPS, E=DR
Checksum	*6B		
EOL	<CR> <LF>		End of message termination

NMEA CMD List

NMEA CMD TYPE	NMEA CMD Example:
Hot Restart	\$PMTK101*32<CR><LF>
Warm Restart	\$PMTK102*31<CR><LF>
Cold Restart	\$PMTK103*30<CR><LF>
Full Cold Restart	\$PMTK104*37<CR><LF>
port baudrate	\$PMTK251,38400*27<CR><LF>

Skylab M&C Technology Co., Ltd.

Address: 9th Floor, Zhongguang Building, Yayuan Road, Bantian, Shenzhen

Phone: 86-755 8340 8210 (Sales Support)

Phone: 86-755 8340 8130 (Technical Support)

Fax: 86-755-8340 8560

E-Mail: sales1@skylab.com.cn

Website: www.skylab.com.cn